

PILOT OPERATED CHECK, SINGLE, MANUAL SHUT-OFF

VSO-SE-DL-DX

05.52.27 - X - Y - Z

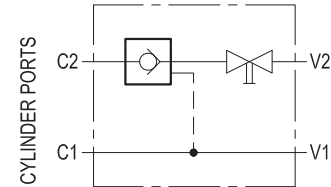
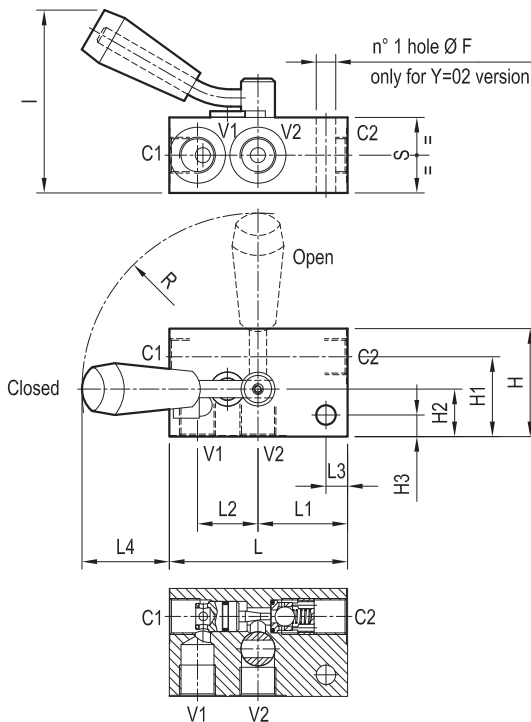

TECHNICAL DATA

Operating pressure: up to 210 bar (3000 psi)

Max flow: see performance graph

Aluminium body

NOTE: aluminium bodies are often strong enough for operating pressures exceeding 210 bar (3000 psi), depending from the fatigue life expected in the specific application. In if doubt, consult our Service Network.

[mm (inches)]

35 (1.38)	40.5 (1.6)	-	35 (1.38)	40.5 (1.6)	90.5 (3.56)	85 (3.35)	-	30 (1.18)	50 (1.97)	65 (2.56)	-	82 (3.23)	G 1/2	3.6 : 1	1 (2.2)
35 (1.38)	40.5 (1.6)	10 (0.39)	28 (1.1)	41.5 (1.63)	82.5 (3.25)	85 (3.35)	10 (0.39)	22 (0.87)	37 (1.46)	50 (1.97)	9 (0.35)	82 (3.23)	G 3/8	5.4 : 1	0.6 (1.3)
S	L4	L3	L2	L1	L	I	H3	H2	H1	H	F	R	Y	Pilot ratio	Weight kg (lbs)

A tap, manually controlled by the operator, allows inlet flow from V2 to pass through the check valve to C2: as a result, the motion of the actuator (typically the extension and positioning of an outrigger) happens under the operator's direct sight. The valve is normally closed (checked) and virtually leak-free from C2 to V2 in order to prevent reverse motion. Flow outlet from C2 to V2 and reverse motion (i.e. outrigger retraction or lifting up) is possible with manual tap open and if sufficient pilot pressure is present at V1-C1 so that the pilot piston may push the poppet from its seat.

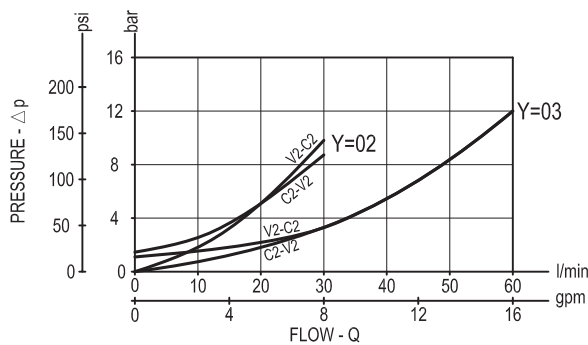

X O-RING ON PILOT PISTON

10 With O-Ring

Z

SPRINGS

Z		SPRINGS	
		Cracking pressure bar (psi)	Ordering code
00	Y=02	1.6 (23)	03.51.01.107
	Y=03	0.6 (9)	03.51.01.107

Y

PORT SIZE

Y		PORT SIZE
		V1-V2-C1-C2
02		G 3/8
03		G 1/2